

## 2 way ball valve S4 with integrated Praher Labeling System



Symbol photo



### Safety locking handle system

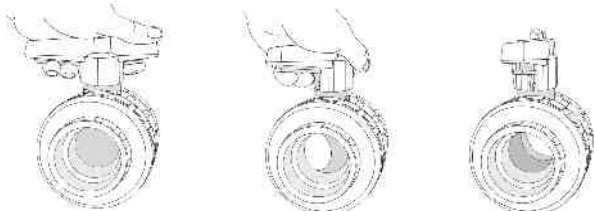

This document does not constitute a guarantee, it is for initial information purposes only. The product range is continually upgraded, the designs and types therefore only reflect the state of the art at the time of printing. Subject to technical modifications!

### General:

- Material: PVC-U / PP / PVDF
- Seal material: EPDM / FPM
- Ball seating joint: PTFE
- Dimensions: DN10 – DN80  
d16 – d110  
3/8" – 4"

### Connector types:

#### PVC

- Solvent socket: DIN / ASTM / JIS
- Solvent spigot: DIN
- Threaded socket: BSP / NPT
- PE Fusion socket: DIN
- PE Fusion spigot: DIN
- Fixed flange: DIN / ANSI / JIS
- Backing flange: DIN  
(on request)

#### PP

- Fusion socket: DIN / ASTM
- Fusion spigot: DIN
- Threaded socket: BSP / NPT
- PE Fusion socket: DIN
- PE Fusion spigot: DIN
- Backing flange: DIN  
(Praher installation length „long“)
- Backing flange: DIN / ANSI  
(on request)
- Fixed flange: DIN / ANSI / JIS  
(on request)

#### PVDF

- Fusion socket: DIN / ASTM
- Fusion spigot: DIN
- Threaded socket: BSP / NPT
- Backing flange: DIN / ANSI  
(on request)

### Operating pressure:

- |                                  |         |
|----------------------------------|---------|
| DN10 d16 3/8" – DN65 d75 d2 1/2" | PN16/10 |
| DN80 d90 3"                      | PN10/6  |
| DN80 d110 4"                     | PN6     |

### Technical features:

- Safety locking handle system
- Radial installation or removal
- Double sided blocked ball
- Machined ball
- Full section area of flow (nominal bore)
- Floating ball

## 2 way ball valve S4 with integrated Praher Labeling System



### Dimensions:

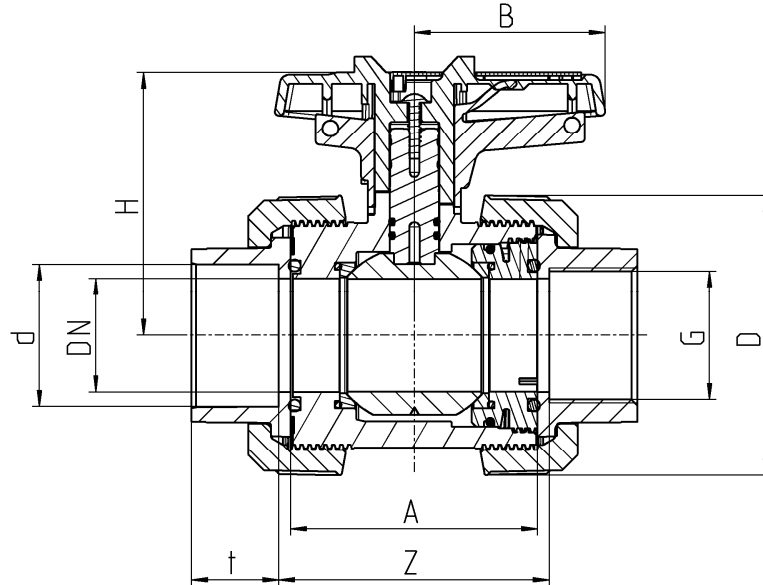

### PVC-U

#### Connector types

PVC solvent socket / threaded socket  
PE fusion socket

DN	10	15	20	25	32	40	50	65	80	80
d	16	20	25	32	40	50	63	75	90	110
<b>G</b> TSO <sup>1</sup>	3/8"	1/2"	3/4"	1"	1 1/4"	1 1/2"	2"	2 1/2"	3"	-
<b>A</b>	62	62	70	74	84	95	109	137	163	163
<b>B</b>	40	40	51,5	51,5	64	73	85	110	132	132
<b>D</b>	53	53	63	70	85	101	124,5	155	188	188
<b>H</b>	72	72	78,5	81,5	100	107,5	116,5	144	163	163
<b>t</b> SSO <sup>1</sup>	16,5	16,5	19,5	22,5	26,5	31,5	38,5	45	55,5	64
<b>t</b> FSO <sup>3</sup> PE	14,5	16	17	19,5	22	25	29	34,5	37,5	41,5
<b>Z</b> SSO <sup>2</sup>	68	67	76	80	91	104	120	148	180	173
<b>Z</b> TSO <sup>1</sup>	67	67	77	81	90	104	120	150	185	-
<b>Z</b> FSO <sup>3</sup> PE	71	68	80	79	98	115	137	165	210	210
<b>PN</b>	16	16	16	16	16	16	16	16	10	6

Dimensions in mm

- <sup>1</sup> TSO = threaded socket
- <sup>2</sup> SSO = solvent socket
- <sup>3</sup> FSO = fusion socket
- = currently not realised

## 2 way ball valve S4 with integrated Praher Labeling System

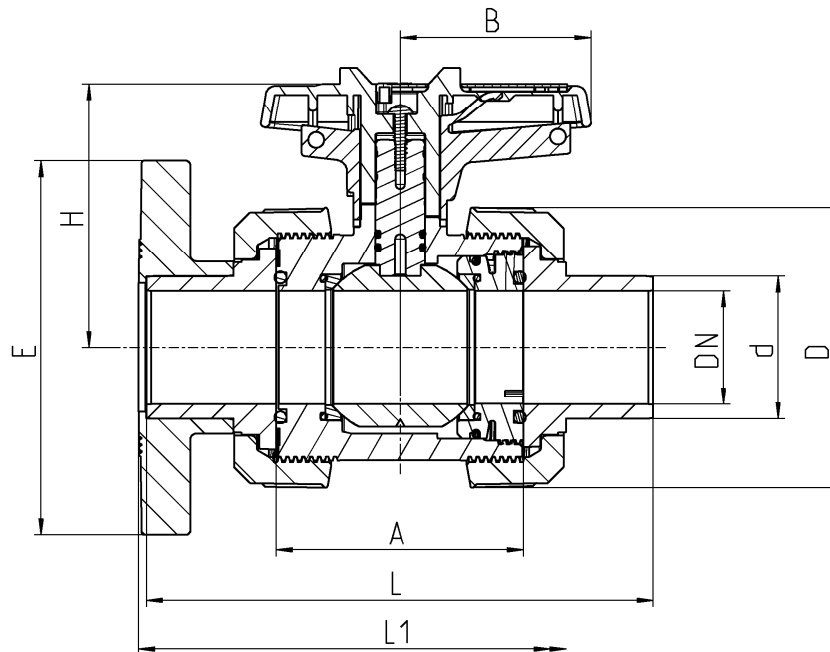

**PVC-U**  
Anschlussvarianten  
PVC solvent spigot  
PE fusion spigot  
PVC fixed flange

DN	10	15	20	25	32	40	50	65	80	80
d	16	20	25	32	40	50	63	75	90	110
A	62	62	70	74	84	95	109	137	163	163
B	40	40	51,5	51,5	64	73	85	110	132	132
D	53	53	63	70	85	101	124,5	155	188	188
H	72	72	78,5	81,5	100	107,5	116,5	144	163	163
E <sup>FF</sup> <sup>1</sup>	-	97	105	125	140	150	165	185	200	229
L <sup>SSP</sup> <sup>2</sup>	115	125	145	154	174	194	223	287	300	341
L <sup>FSP</sup> <sup>3</sup> PE	112	123	143	151	142	180	197	253	293	323
L1 <sup>FF</sup> <sup>1</sup>	120	130	150	160	180	200	230	290	310	350
PN	16	16	16	16	16	16	16	16	10	6

Dimensions in mm

- <sup>1</sup> FF = fixed flange
- <sup>2</sup> SSP = solvent spigot
- <sup>3</sup> FSP = fusion spigot
- = currently not realised

## 2 way ball valve S4 with integrated Praher Labeling System

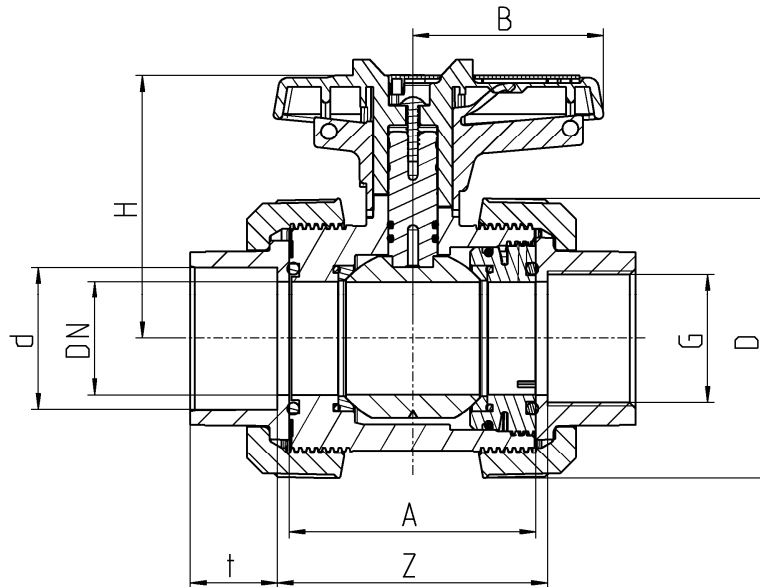

### PP

#### Connector types

PP fusion socket / threaded socket

PE fusion socket

DN	10	15	20	25	32	40	50	65	80	80
d	16	20	25	32	40	50	63	75	90	110
G <sup>TSO</sup> <sup>1</sup>	3/8"	1/2"	3/4"	1"	1 1/4"	1 1/2"	2"	2 1/2"	3"	-
A	62	62	69	73	83	94	108	133	160	160
B	40	40	51,5	51,5	64	73	85	110	132	132
D	53	53	64	71	84,5	100	120,5	155	187	187
H	71,5	71,5	77	80,5	98,5	106,5	115,5	142	160	160
t <sup>FSO</sup> <sup>2</sup> PP	14,5	16	17,5	19,5	22	25,5	29	34,5	38,5	42
t <sup>FSO</sup> <sup>2</sup> PE	14,5	16	17	19,5	22	25	29	34,5	37,5	41,5
Z <sup>TSO</sup> <sup>1</sup>	67	67	74	80	89	103	119	143	180	-
Z <sup>FSO</sup> <sup>2</sup> PP	71	68	78	84	97	113	136	162	211	211
Z <sup>FSO</sup> <sup>2</sup> PE	71	68	79	87	97	114	136	161	207	207
PN	10	10	10	10	10	10	10	10	6	6

Dimensions in mm

<sup>1</sup> TSO = threaded socket

<sup>2</sup> FSO = fusion socket

- = currently not realised

## 2 way ball valve S4 with integrated Praher Labeling System

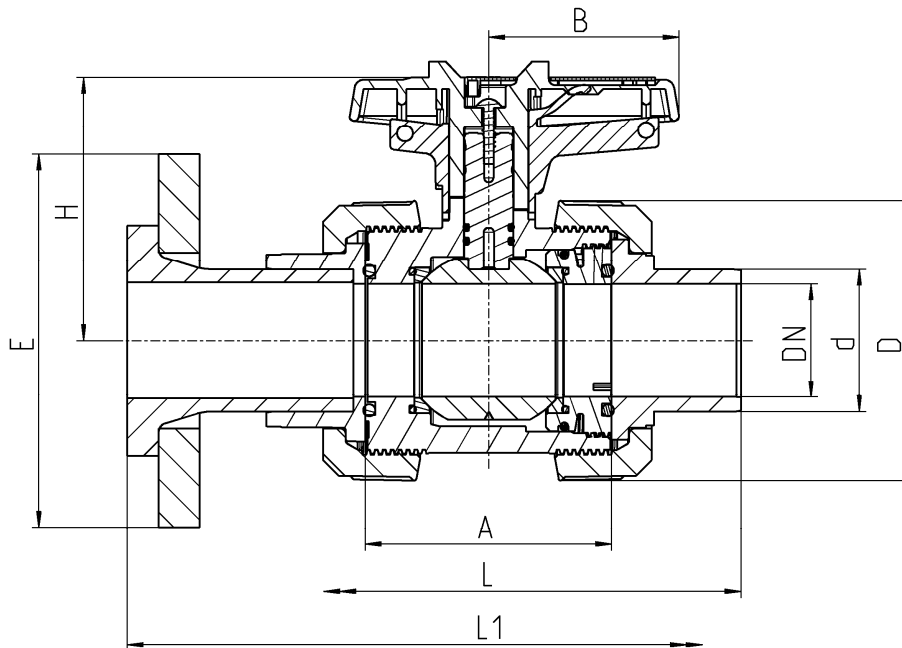

### PP

#### Connector types

- PP fusion spigot
- PE fusion spigot
- PP-GFK backing flange

DN	10	15	20	25	32	40	50	65	80	80
d	16	20	25	32	40	50	63	75	90	110
A	62	62	69	73	83	94	108	133	160	160
B	40	40	51,5	51,5	64	73	85	110	132	132
D	53	53	64	71	84,5	100	120,5	155	187	187
H	71,5	71,5	77	80,5	98,5	106,5	115,5	142	160	160
E <sup>BF<sup>2</sup></sup>	-	95	108	115	140	151	165	186	202	222
L <sup>FSP<sup>1</sup> PP</sup>	114	125	143	152	171	191	220	277	295	312
L <sup>FSP<sup>1</sup> PE</sup>	112	123	142	150	141	179	196	249	290	320
L1 <sup>BF<sup>2</sup></sup>	-	168	185	190	206	321	385	420	380	437
PN	10	10	10	10	10	10	10	10	6	6

Dimensions in mm

- <sup>1</sup>FSP = fusion spigot
- <sup>2</sup>BF = backing flange
- = currently not realised

## 2 way ball valve S4 with integrated Praher Labeling System

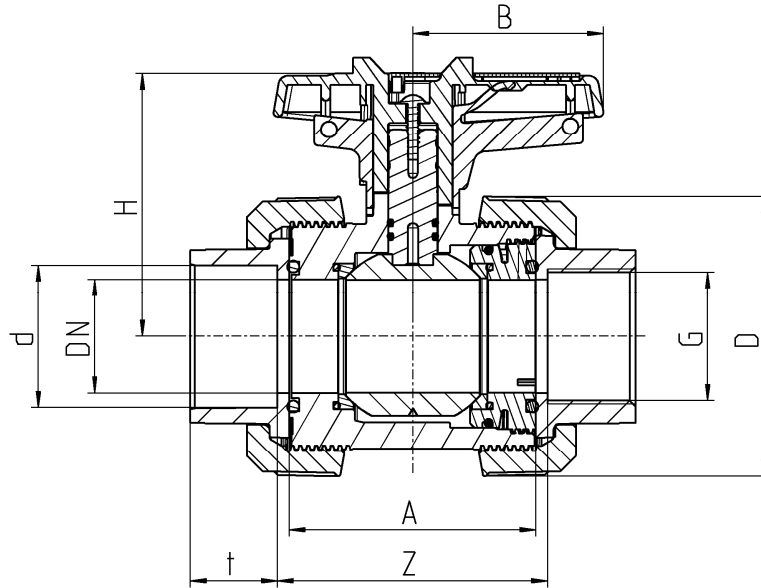

### PVDF

#### Connector types

- PVDF fusion socket
- PVDF threaded socket

DN	10	15	20	25	32	40	50	65	80	80
d	16	20	25	32	40	50	63	75	90	110
<b>G</b> TSO <sup>1</sup>	3/8"	1/2"	3/4"	1"	1 1/4"	1 1/2"	2"	2 1/2"	3"	-
<b>A</b>	62	62	69	73	83	94	108	133	160	160
<b>B</b>	40	40	51,5	51,5	64	73	85	110	132	132
<b>D</b>	52,5	52,5	63	70	85,5	98	118	151	183	183
<b>H</b>	71,5	71,5	77	80,5	98,5	106,5	115,5	142	160	160
<b>t</b> FSO <sup>2</sup>	14,5	16	17	19,5	22	25	29	34,5	38,5	41,5
<b>Z</b> TSO <sup>1</sup>	67	67	74	80	89	103	119	143	180	-
<b>Z</b> FSO <sup>2</sup>	71	68	78	84	97	113	136	162	207	170
<b>PN</b>	16	16	16	16	16	16	16	16	10	6

Dimensions in mm

<sup>1</sup> TSO = threaded socket  
<sup>2</sup> FSO = fusion socket  
 - = currently not realised

## 2 way ball valve S4 with integrated Praher Labeling System

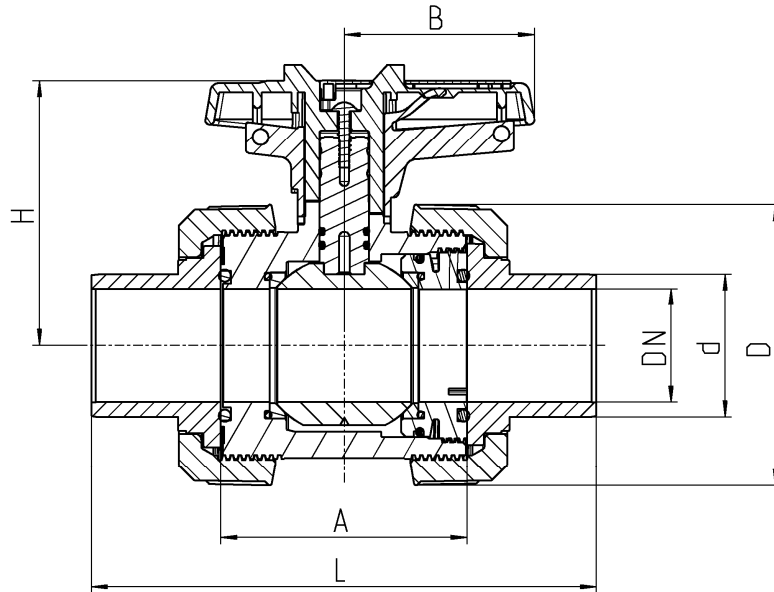

### PVDF

#### Connector types

PVDF fusion spigot

DN	10	15	20	25	32	40	50	65	80	80
d	16	20	25	32	40	50	63	75	90	110
A	62	62	69	73	83	94	108	133	160	160
B	40	40	51,5	51,5	64	73	85	110	132	132
D	52,5	52,5	63	70	85,5	98	118	151	183	183
H	71,5	71,5	77	80,5	98,5	106,5	115,5	142	160	160
L <sub>FSP</sub> <sup>1</sup>	114	125	143	152	171	191	220	297	295	320
PN	16	16	16	16	16	16	16	16	10	6

Dimensions in mm

<sup>1</sup> FSP = fusion spigot

## 2 way ball valve S4 with integrated Praher Labeling System

### Exploded drawing:

- |  |  |
|--|--|
| 01. Handel   | 12. Union nut                            |
| 02. O-Ring   | 13. Flange adaptor / stub flange         |
| 03. Shaft  | 14. Backing flange / fixed flange        |
| 04. Body   | 16. Connection set                       |
| 05. Ball   | 20. Spring loaded locking sleeve         |
| 06. Ball seating joint   | 21. Stub tenor for opening thrust collar |
| 07. O-Ring   | 22. Screw                                |
| 08. O-Ring   | 23. PLS-labeling insert                  |
| 09. Thrust collar  |  |
| 10. O-Ring   |  |
| 11. Connector types<br>solvent socket / solvent spigot<br>fusion socket / fusion spigot<br>threaded socket |  |

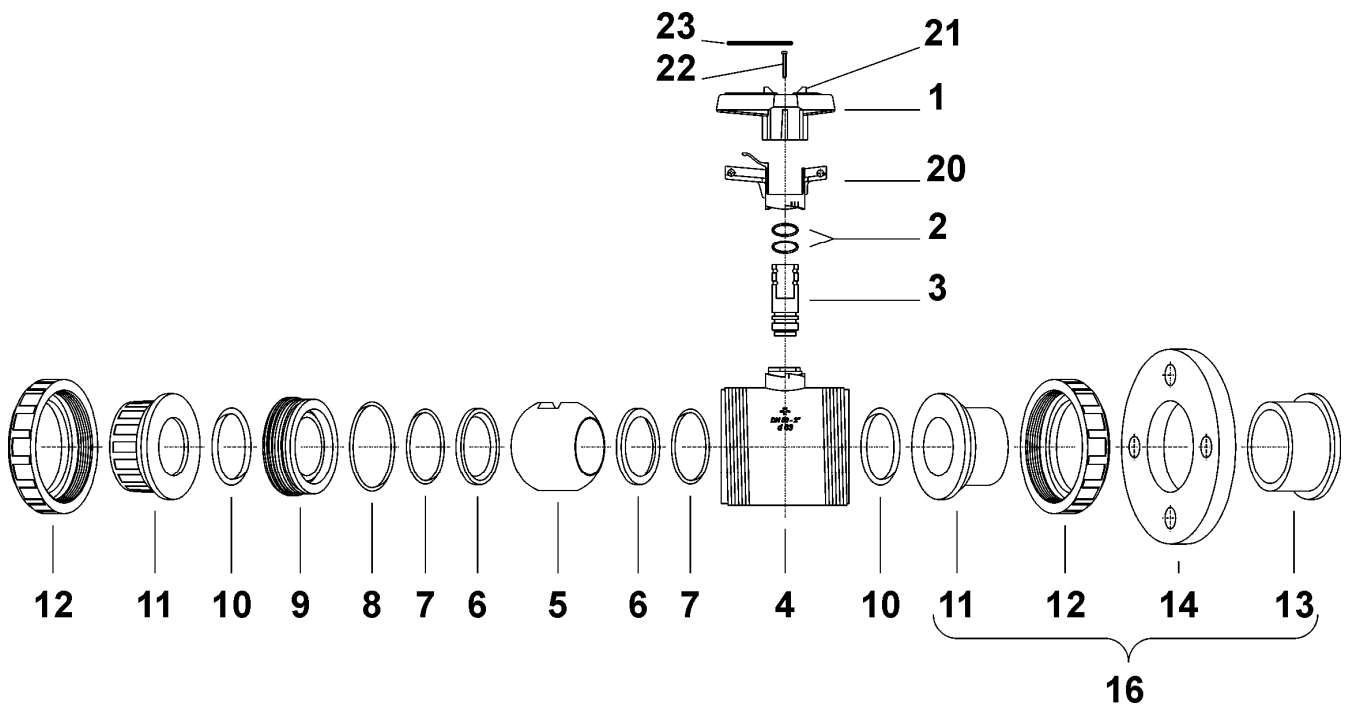



## 2 way ball valve S4 with integrated Praher Labeling System



### Diagrams:

#### Pressure loss diagram

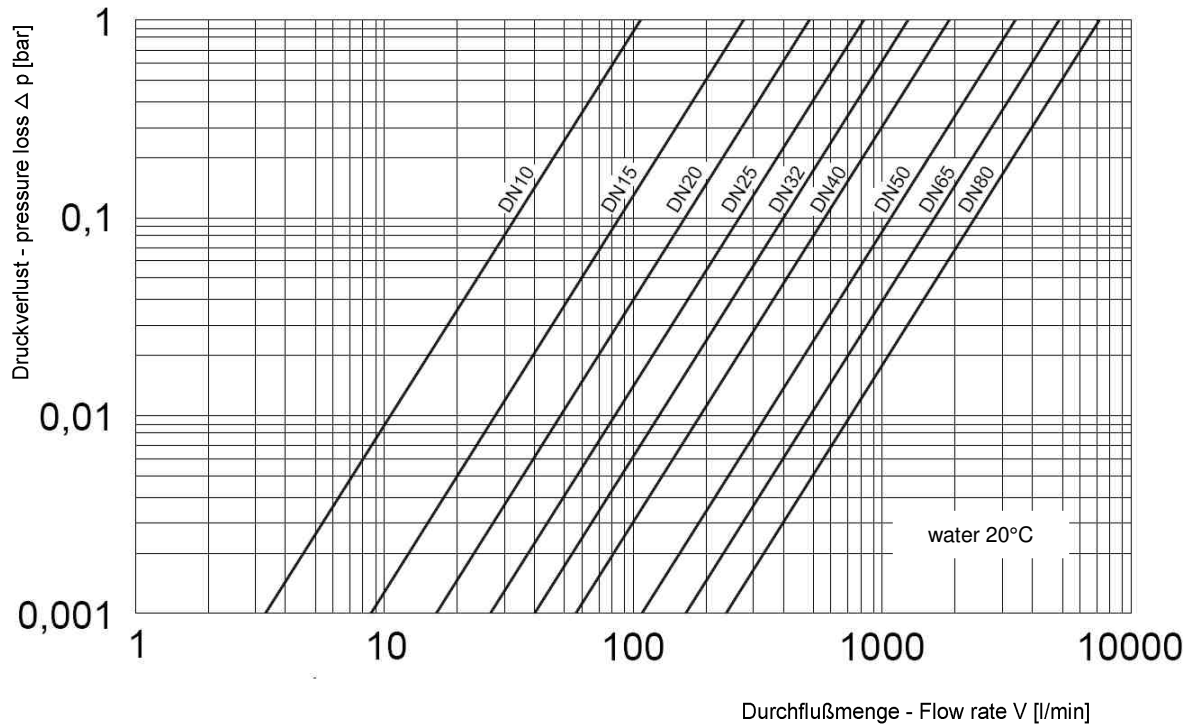

Cv value table		
pressure loss	1 bar	0,001 bar
<b>DN10</b>	107 l/min	3,4 l/min
<b>DN15</b>	278 l/min	8,8 l/min
<b>DN20</b>	509 l/min	16,1 l/min
<b>DN25</b>	843 l/min	26,7 l/min
<b>DN32</b>	1269 l/min	40,1 l/min
<b>DN40</b>	1858 l/min	58,7 l/min
<b>DN50</b>	3424 l/min	110 l/min
<b>DN65</b>	5133 l/min	165 l/min
<b>DN80</b>	7455 l/min	240 l/min

## 2 way ball valve S4 with integrated Praher Labeling System

### Torque

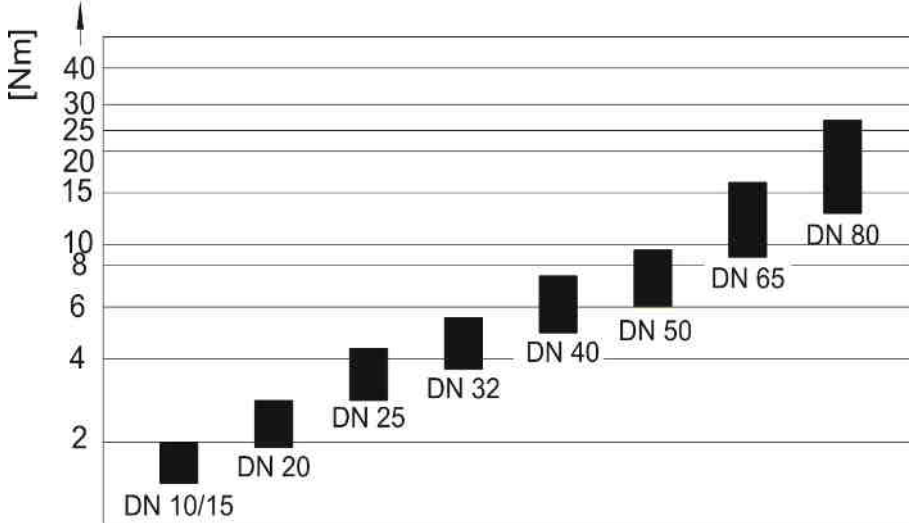

### PVC

#### Flow characteristics

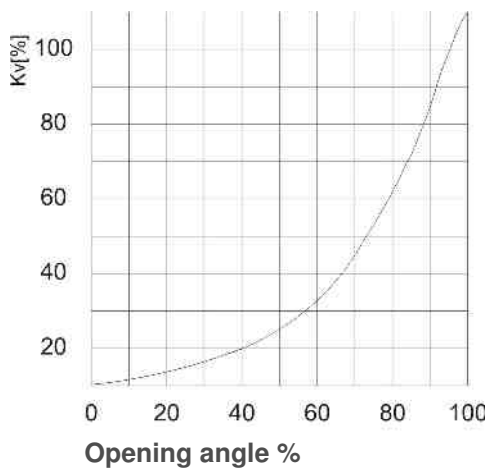

#### Pressure – Temperature – Diagram

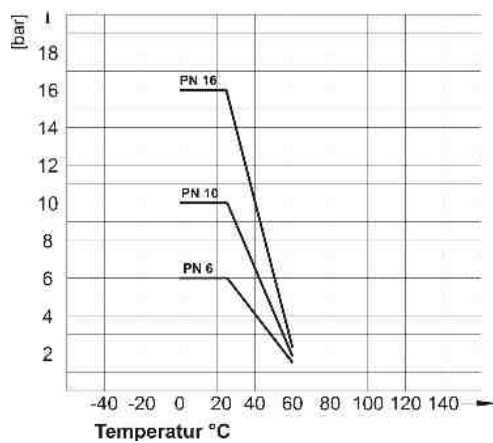

### PP

#### Flow characteristics

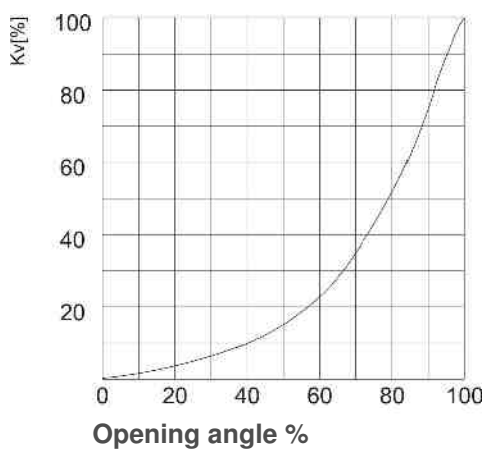

#### Pressure – Temperature – Diagram

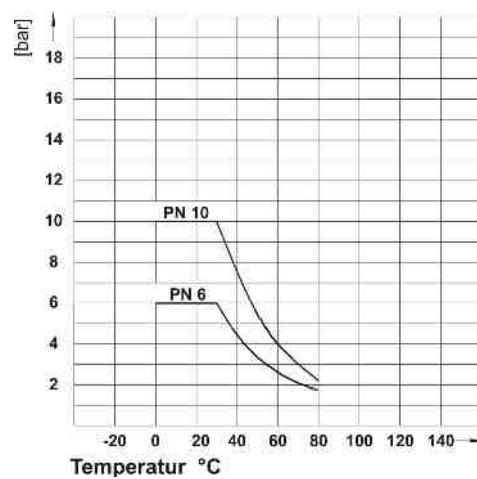

## 2 way ball valve S4 with integrated Praher Labeling System

### PVDF

#### Flow characteristics

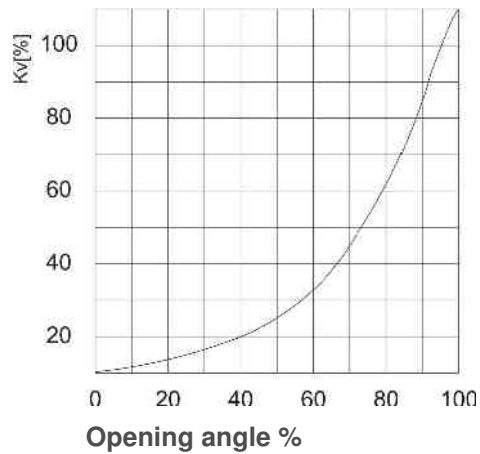

#### Pressure – Temperature – Diagram

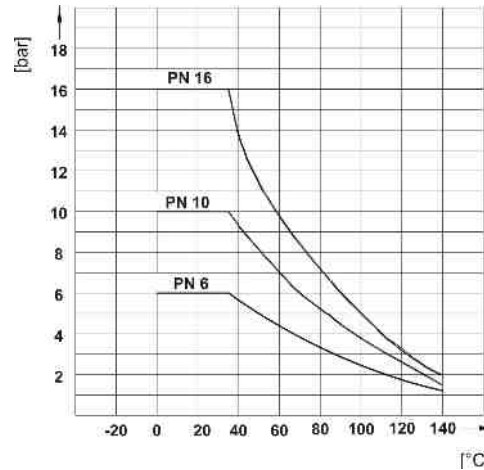

### PLS – Praher Labeling System

#### Technical features:

- Unique durable label
- Reliable labeling by touch-up pen or laser engraving
- Standard version with yellow plate; other colours in red, blue and green
- Simple and easy to exchange
- Corrosion resistant
- Function of valve 100% guaranteed and not effective by PLS

